

10. Radiator.

a. Trim ears from bottom fan shroud (48) as shown.

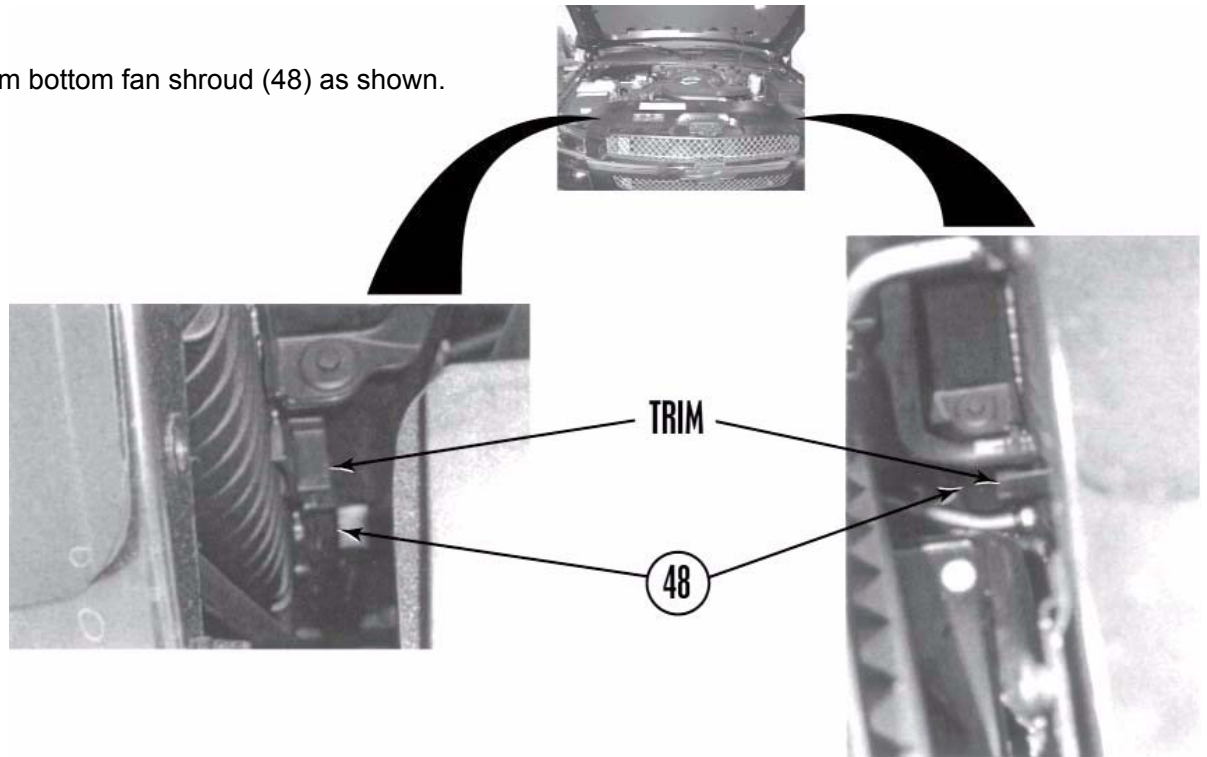

b. Remove two center harness clips (121) from core support (24). Remove two clips from harness (122).

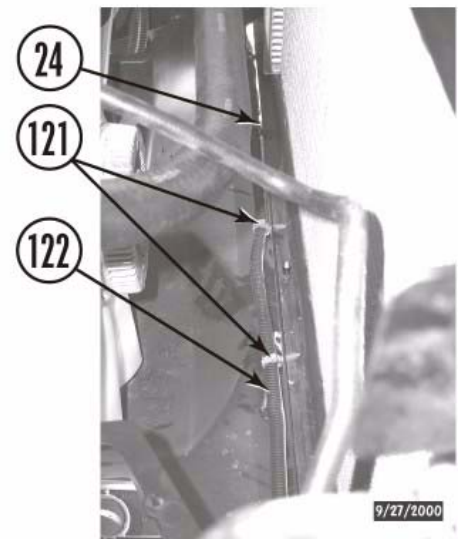

c. Position two *kit* clamps (123) on harness (122).

d. Install two *kit* clamps (123) and two *kit* lower fan shroud mounting brackets (124) on the core support (24) with two *kit* 1/4" x 1" bolts (125), two *kit* 1/4" SAE washers (126), and two *kit* 1/4" nylock nuts (127).

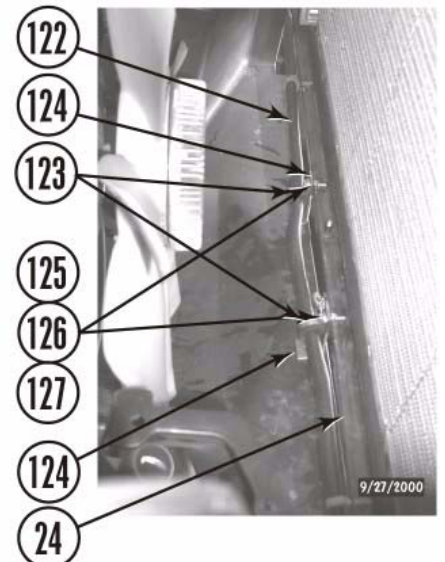

e. Install two *kit* upper fan shroud mounting brackets (128) on core support (24) with two bolts with captive washers (45). Do not tighten.

f. Install top fan shroud (47) on *kit* mounting brackets (128) with two *kit* 1/4" SAE washers (126) and *kit* 1/4" nylock nuts (127). Do not tighten.

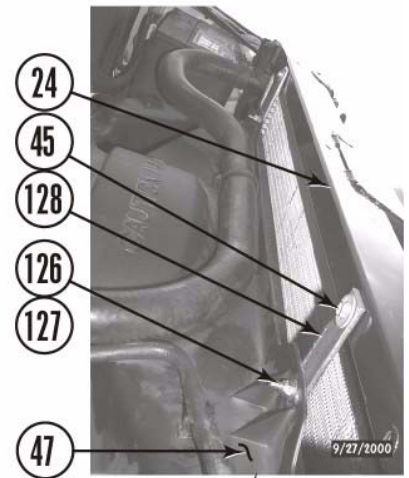

g. Install top fan shroud (47) on bottom fan shroud (48) with four popups (46).

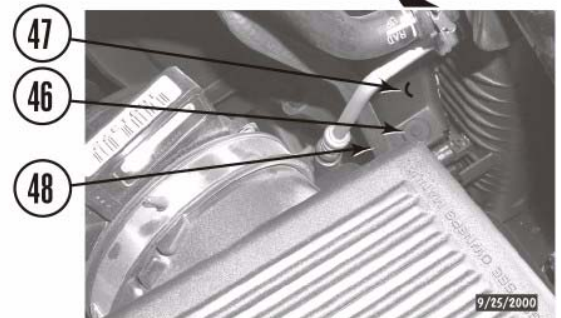

h. Using two *kit* lower fan shroud support brackets (124) as a template, mark and drill two 5/16" holes in the bottom fan shroud (48) from front of vehicle up through shroud as shown.

i. Install bottom fan shroud (48) on two *kit* lower fan shroud support brackets (124) with two *kit* 1/4 x 1" bolts (125), four *kit* 1/4" SAE washers (126), and two *kit* 1/4" nylock nuts (127). Ensure bolt threads point out of shroud.

j. Check fan to fan shroud clearance. Ensure gap is the same all around shroud and tighten bolts (125) and nuts (127).

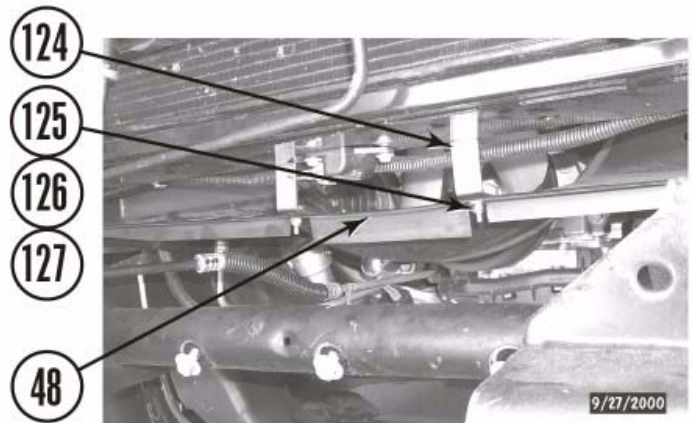

k. Position air duct (42) on air filter housing (43) and throttle body (44) and tighten two clamps (40 and 41).

l. Install two hoses (35 and 36) in three clamps (37, 38, and 39).

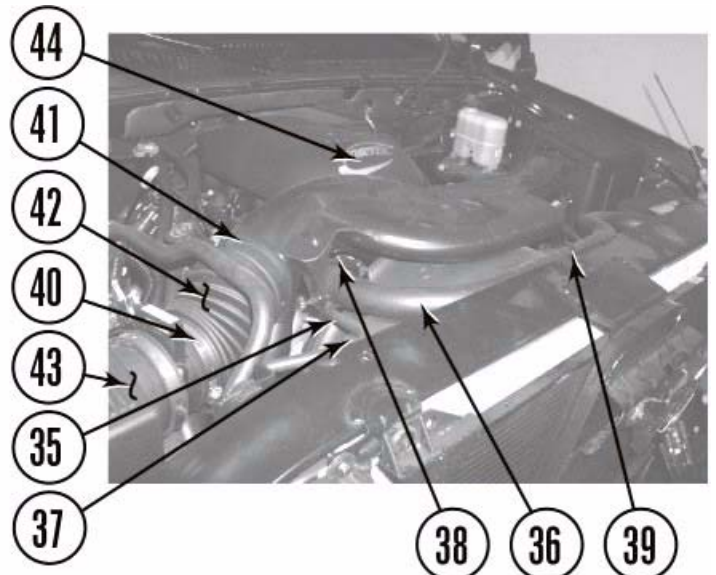

11. Install the front bumper.

a. Trim the two front frame crush zones (129) as shown.

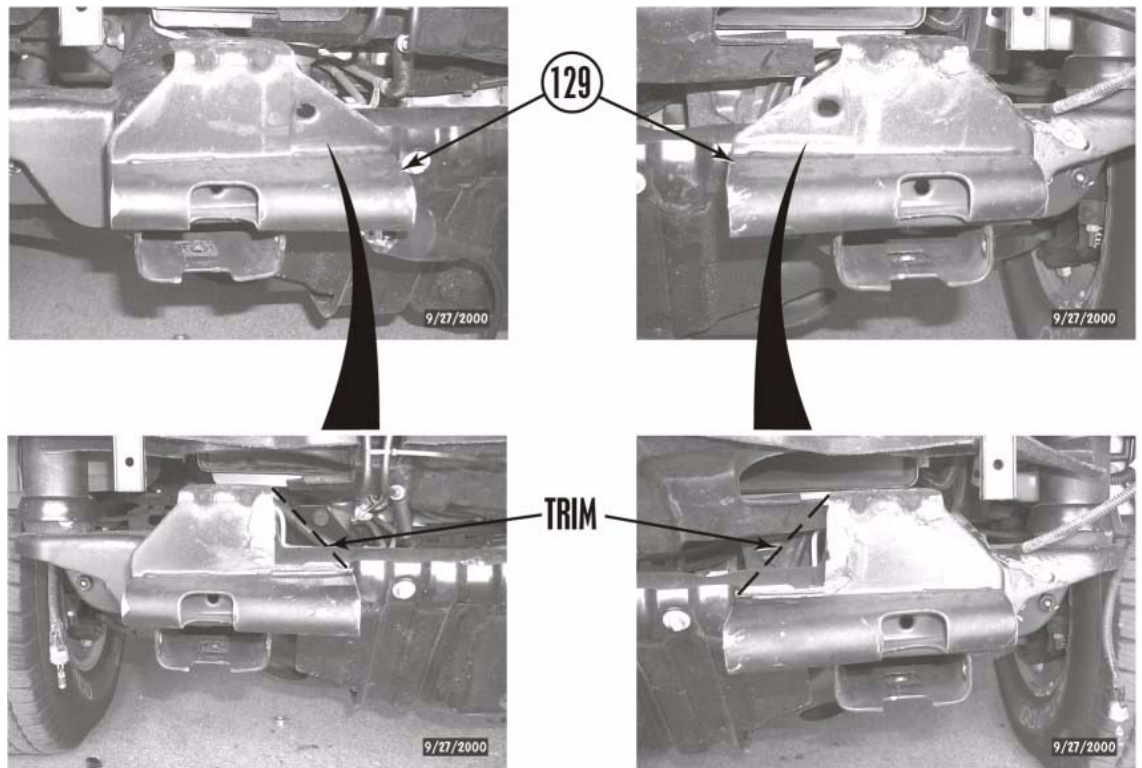

b. Trim the core support (24) in four places as shown.

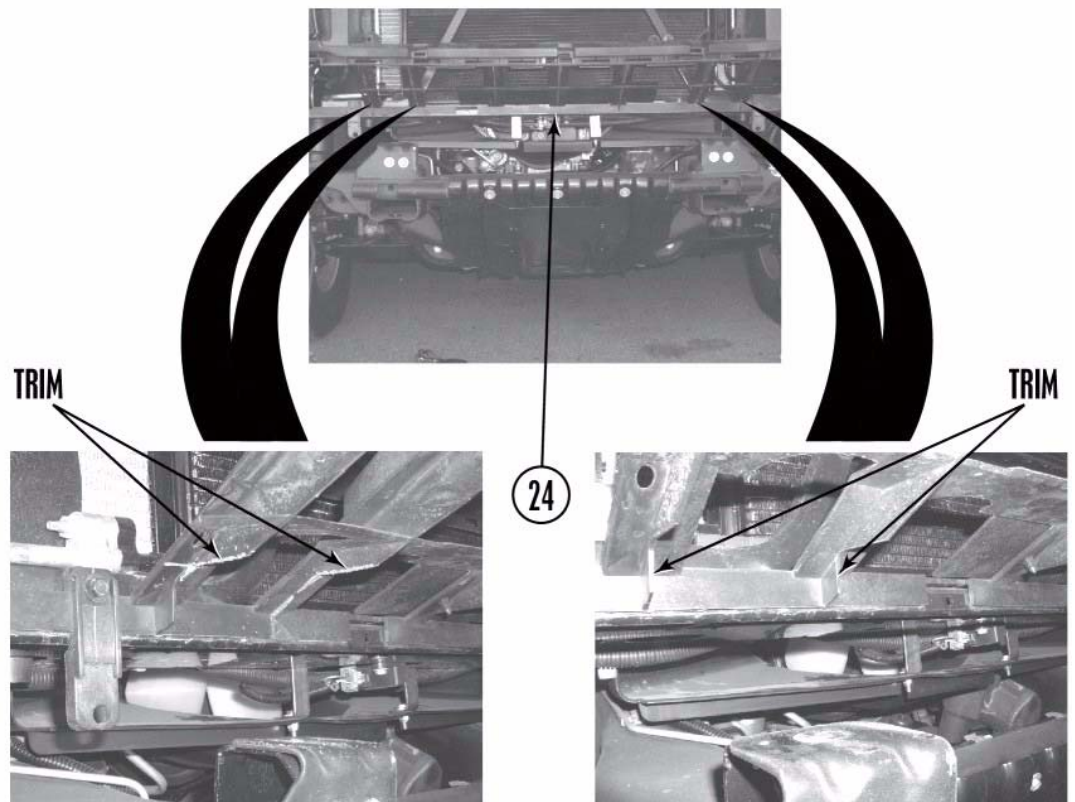

c. Coat threads of bolts (28 and 131) and nuts (133) with Loctite®.

d. Install two *kit* bumper brackets (130) on frame (29) with two stock bolts with captive washers (28), two *kit* 7/16" x 1 1/2" bolts (131), four *kit* 7/16" USS washers (132), and two *kit* 7/16" nylock nuts (133). Do not tighten.

e. Install *kit* small bumper brackets (134) on *kit* bumper brackets (130) with four *kit* 7/16" x 1 1/2" bolts (131), eight *kit* 7/16" USS washers (132), and four *kit* 7/16" nylock nuts (133). Do not tighten.

f. Install front inner bumper (25) on two *kit* bumper brackets (130) and two *kit* small bumper brackets (134) with two stock bolts with captive washers (28), two *kit* 7/16" x 1 1/2" bolts (131), four *kit* 7/16" USS washers (132), and two *kit* 7/16" nylock nuts (134).

g. Tighten nuts (133) and bolts (28 and 131).

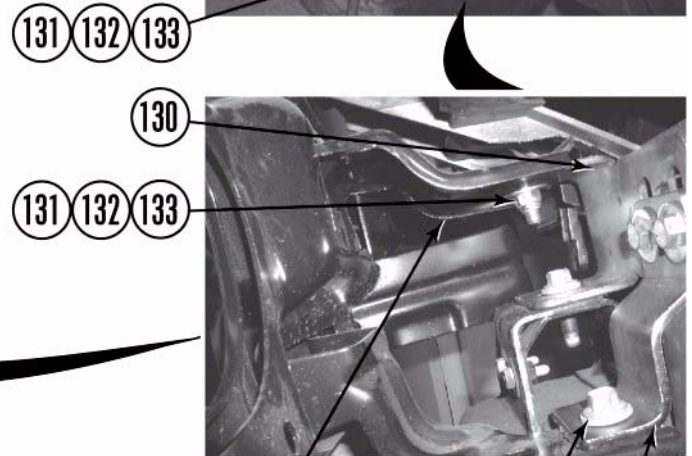
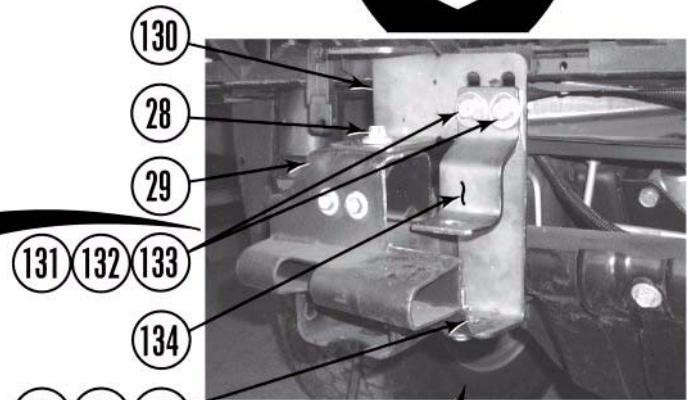
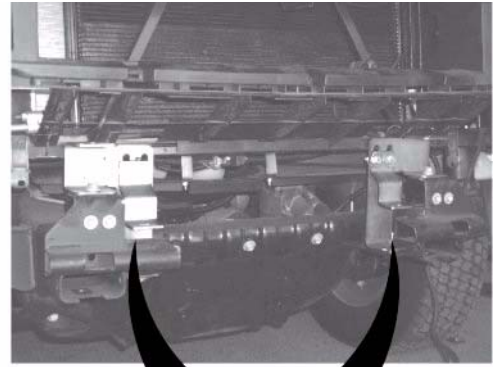

25

h. Position grille (8) on front of vehicle, click two clips (27) into two front fenders (11), and two more clips (26) into core support (24).

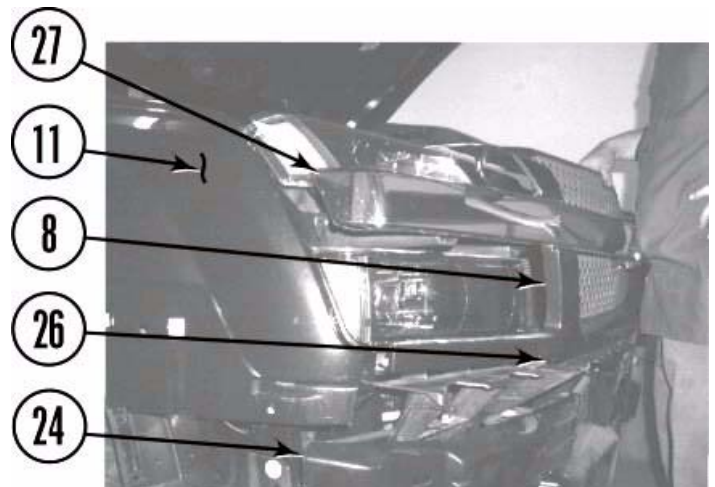

i. Position front outer bumper (10) over front inner bumper (25) and click fourteen clips (23) into two front fenders (11), core support (24), front inner bumper (25), and grille (8).

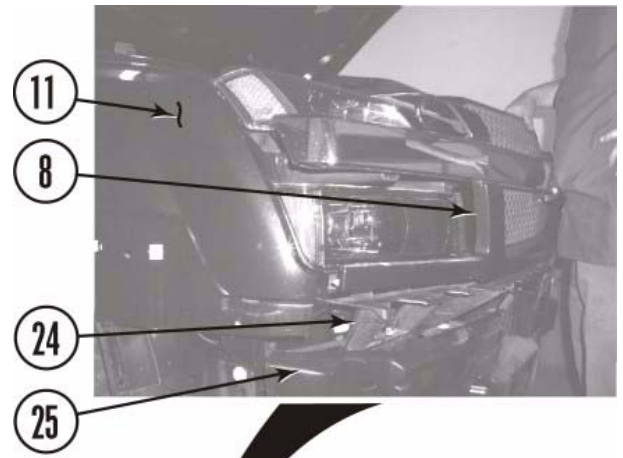

j. Click four clips (22) into two front fenders (11).



k. Install four connectors (20) in two fog lamps (21) and four push clips (18) in bumper brackets (19).

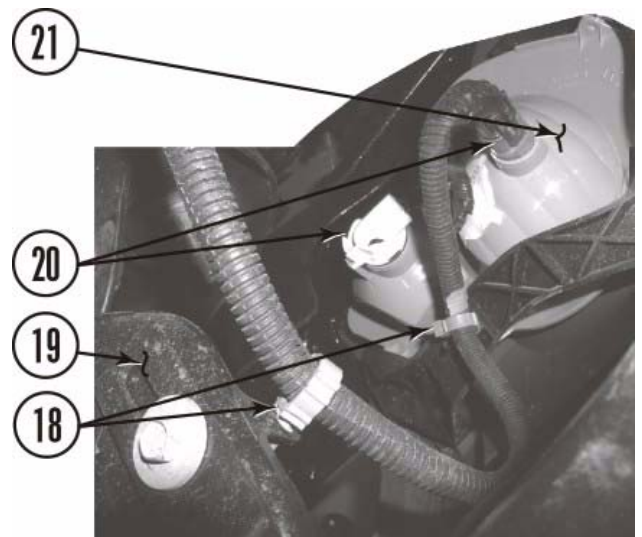
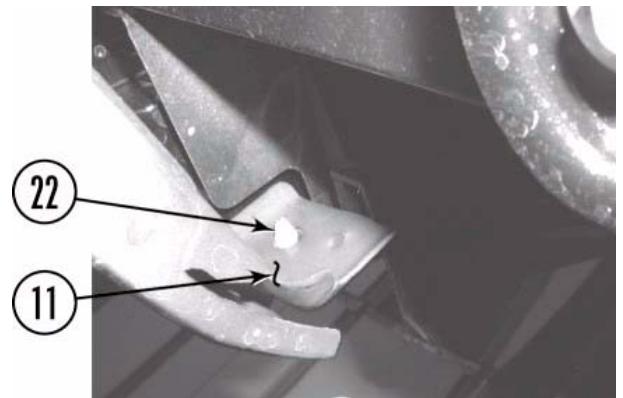

l. Install two side brackets (16) on frame (29) with four bolts (15) (note that bolts now go in bracket center holes).

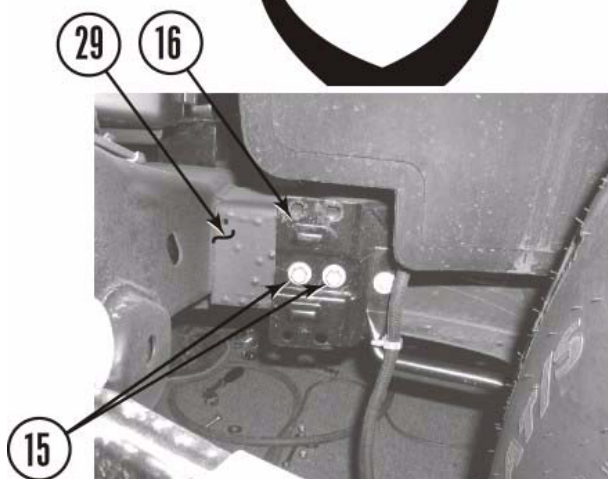

m. Install bracket (13) on shroud (14) with two bolts with captive washers (12).



n. Install front outer bumper (10) on two front fenders (11) with eight screws (9).

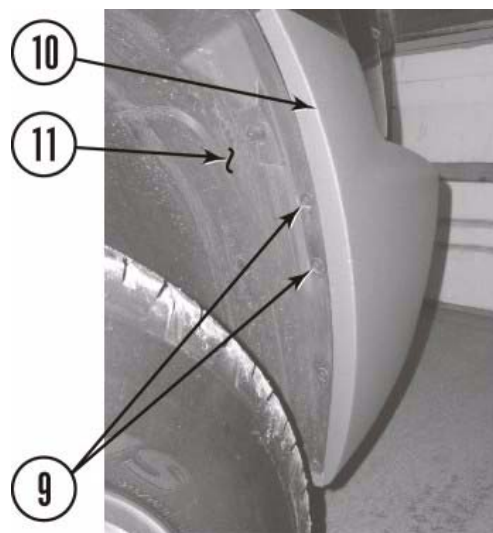

- o. Install three popups (7) in grille (8).
- p. Check measurements between front bumper (15) and front fenders (14). Adjust bumper to body clearance and tighten bolts and nuts to 55 lb-ft.

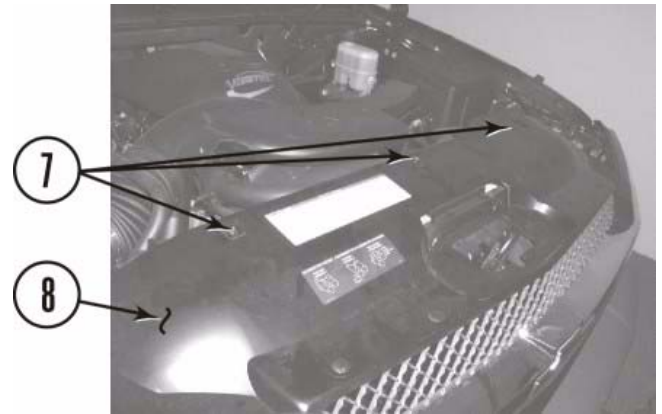

⚠WARNING
 The following procedure is intended only to enhance the appearance of the vehicle. The rear bumper will no longer be rated for towing of any kind. Towing with the rear bumper after it has been lifted can result in death, serious personal injury, or damage to the vehicle. Towing after the bumper has been lifted should be accomplished using a rated Class III receiver type hitch.

12. Install the rear bumper.

- a. Trim spare tire carrier (135) as shown.

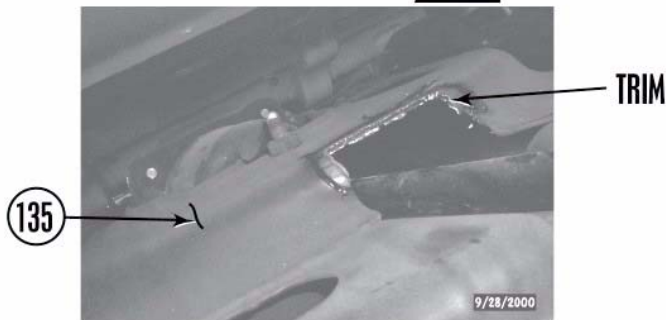

- b. Remove tailgate (84) from bed (81).
- c. Remove two screws (136) from molding (137) and bed (81).

